

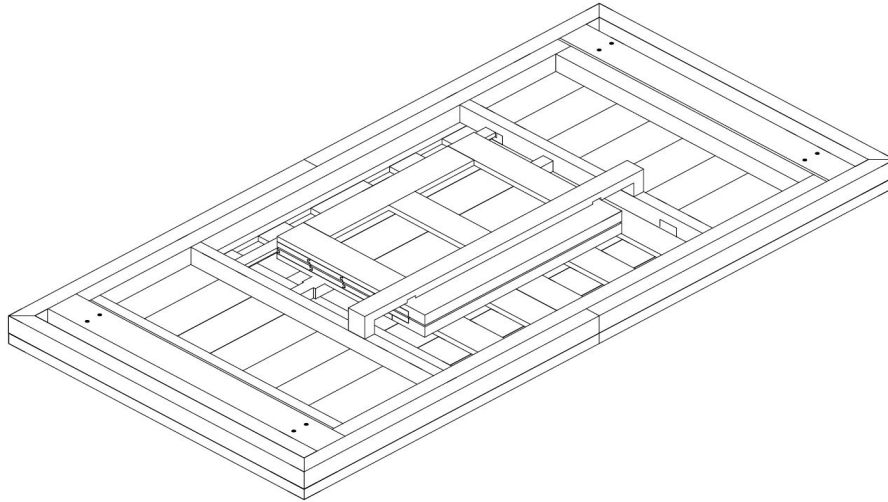

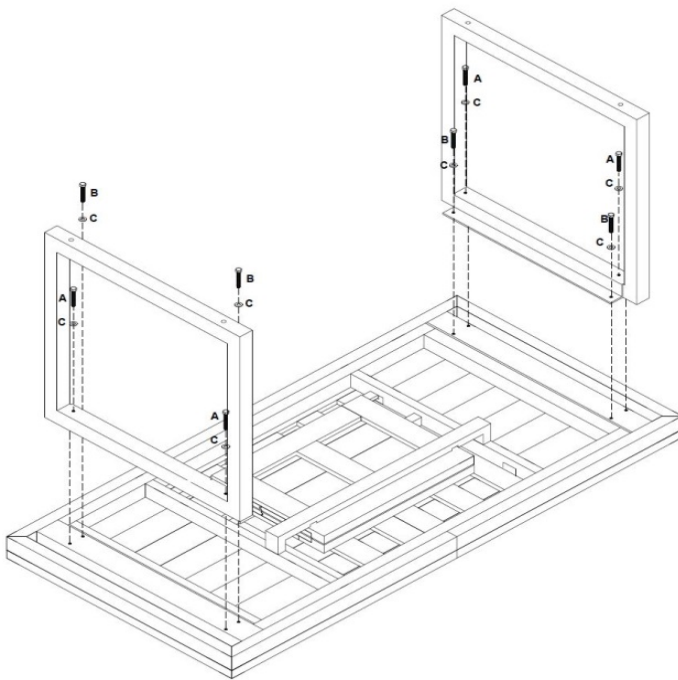

Assembly requires two adults.

*Lay all parts on a blanket to prevent scratching.
Carefully lift each part*



STEP 1 We suggest to place the table upside down on a blanket to protect it from scratching. Unlock locking clips



	HARDWARE		QUANTITY
A	BOLT Φ 10 x 80		4
B	BOLT Φ 10 x 40		4
C	WASHER Φ 11 x 26 x 1.8		8
D	RING SPANNER K17 x 25 x 135		1

STEP 2 Attach the legs using bolt (A), bolt (B) and washer ©
Table legs are self adjusting moving the leg up or down the elongated bolt hole in the table top corner block.
It is best to completely tighten each bolt when the table is assembled in the upright position.

STEP 3 Tighten all bolts by using ring spanner (D), do not use power tool

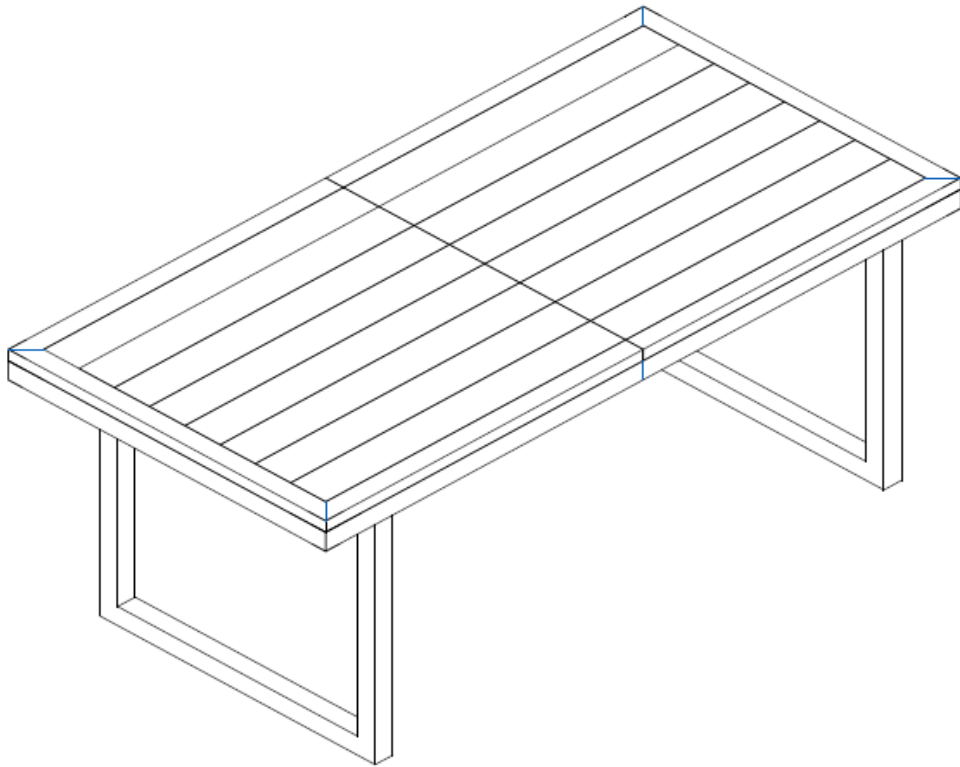

STEP 4 Carefully turn the table over on to its feet, and tighten all bolts.

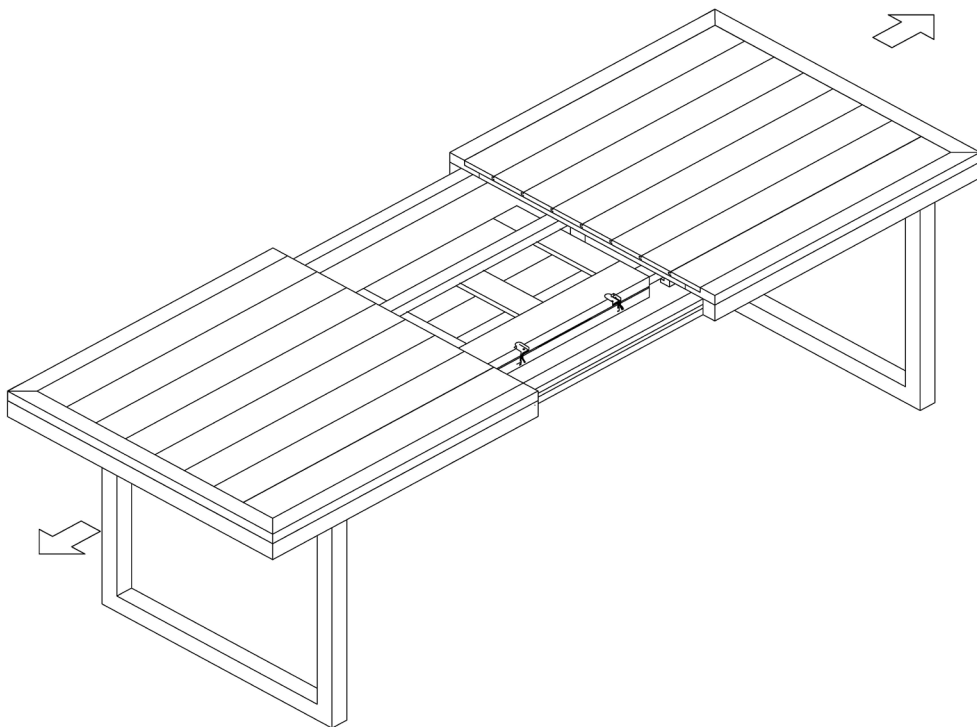

STEP 5 Open the table top.

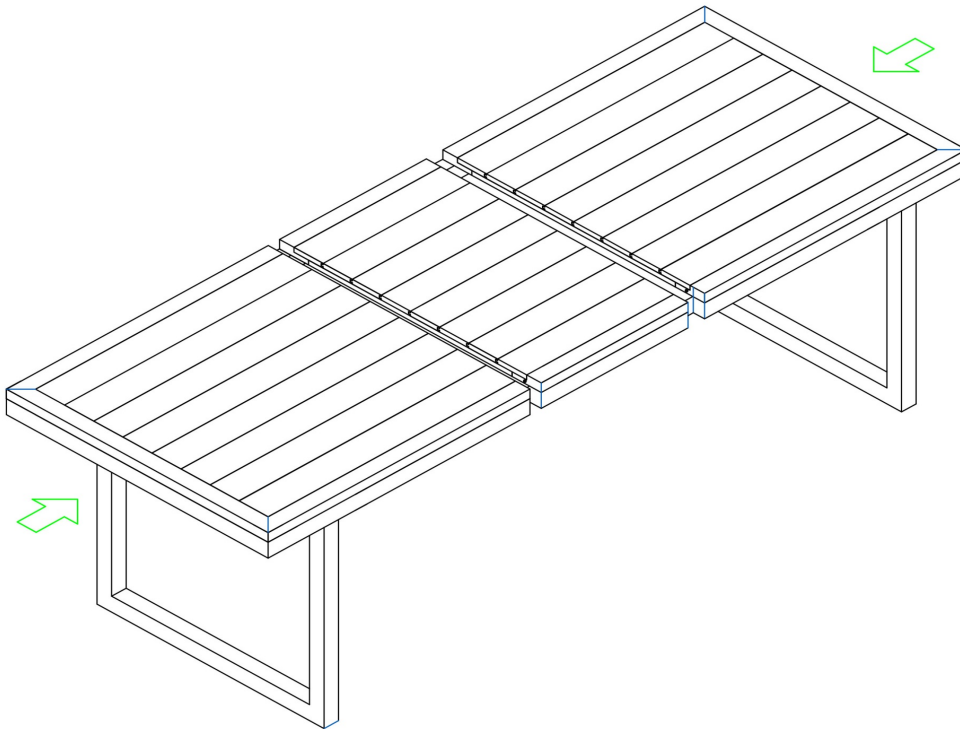

STEP 6 Fully open the leaf and close the table top

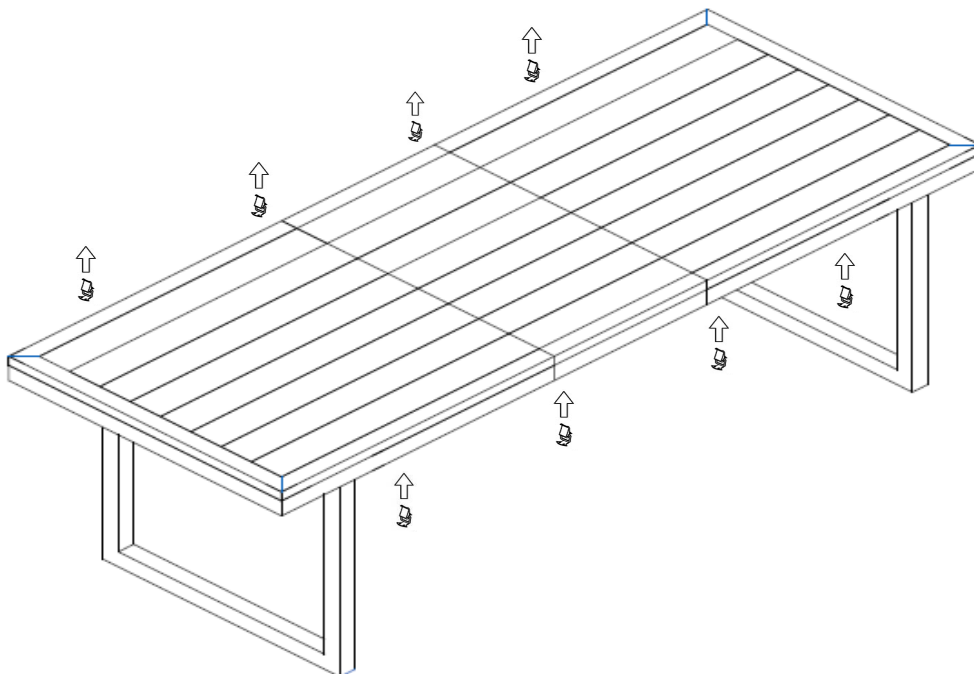

STEP 7 Lock locking clips