

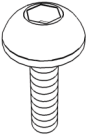

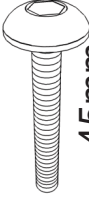

Paris 2,5 chaiselong

<p>(A)</p>  <p>20mm</p> <p>X12</p>	<p>(B)</p>  <p>45mm</p> <p>X1</p>	<p>(C)</p>  <p>M6</p> <p>X1</p>	<p>(D)</p>  <p>X4</p>	<p>(E)</p>  <p>X1</p>	<p>(F)</p>  <p>7.5 cm</p> <p>X8</p>
<p>(G)</p>  <p>65mm</p> <p>X1</p>	<p>(H)</p>  <p>45mm</p> <p>X4</p>	<p>(I)</p>  <p>26mm</p> <p>X4</p>			

1

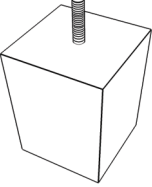
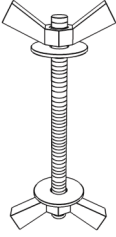
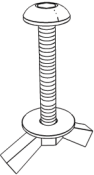
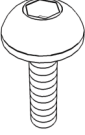
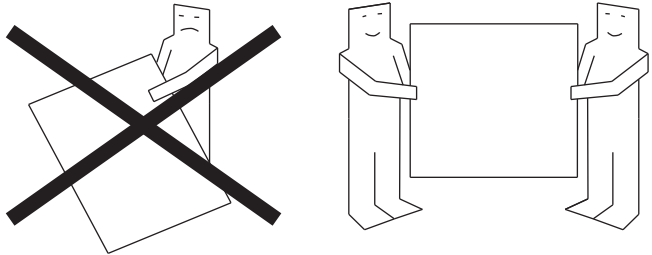
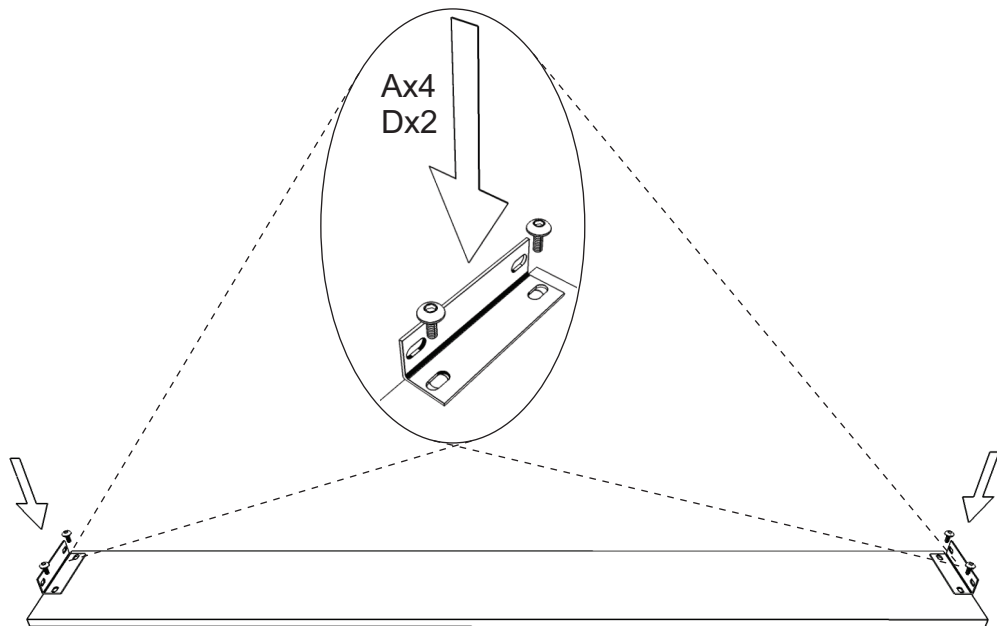

2

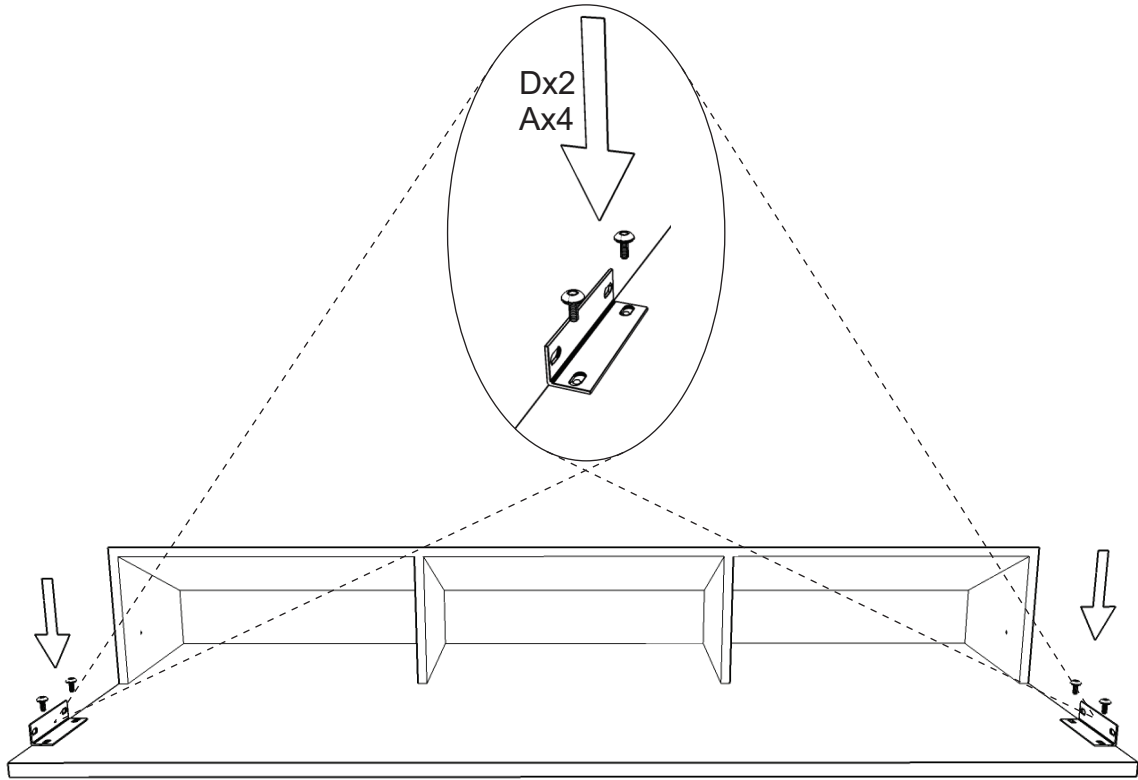

3

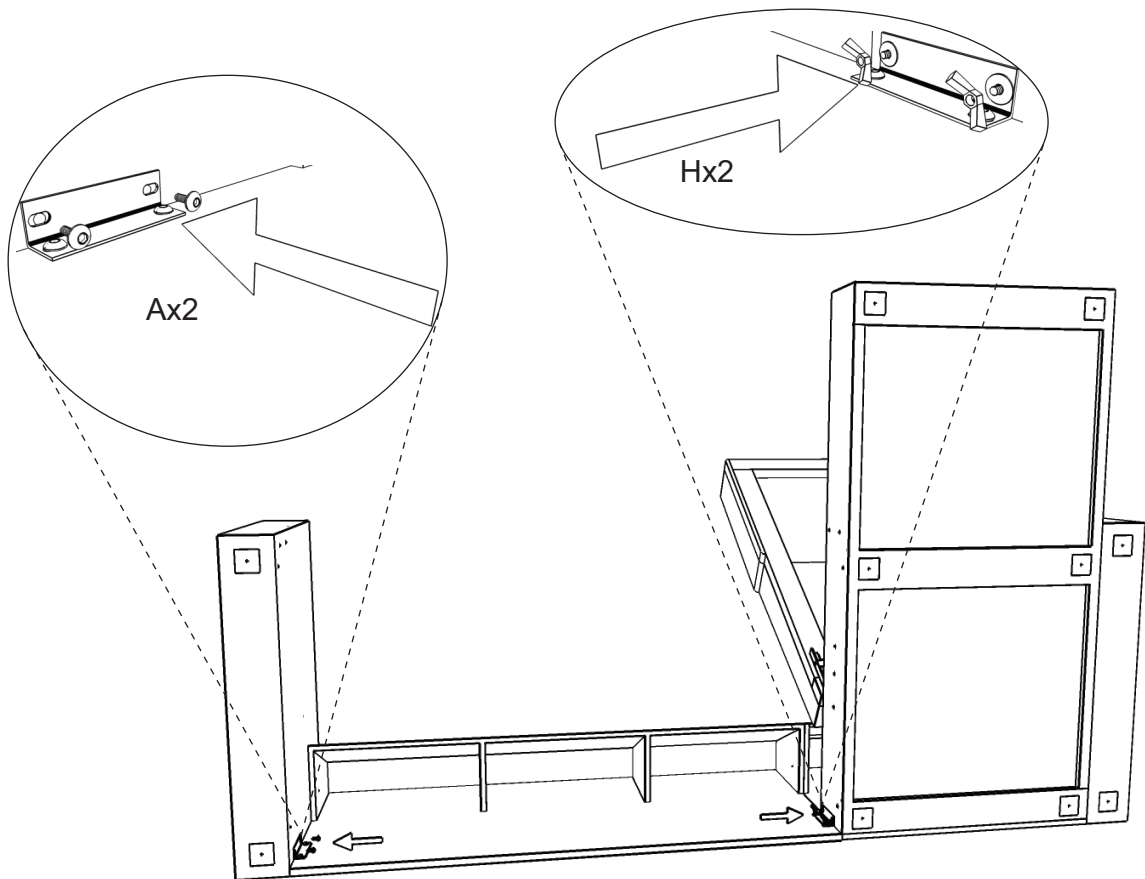

4

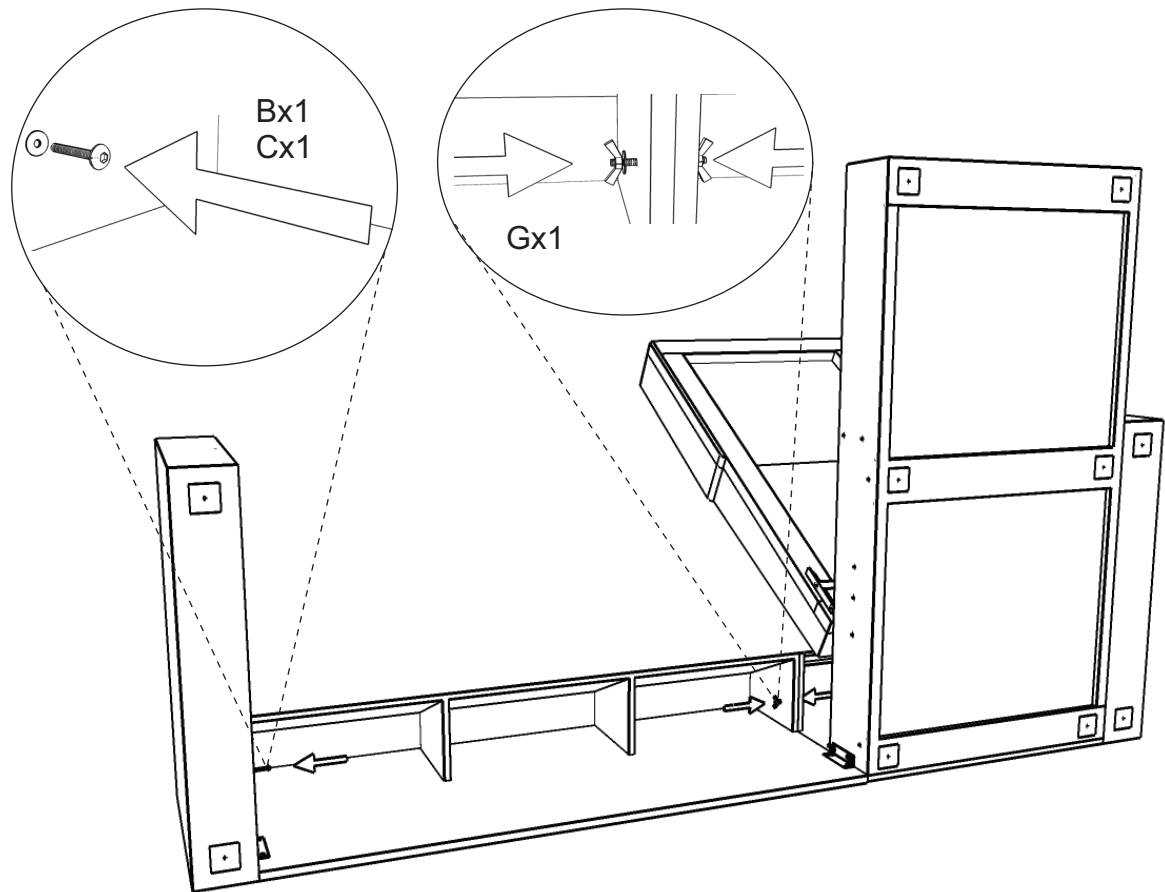

5

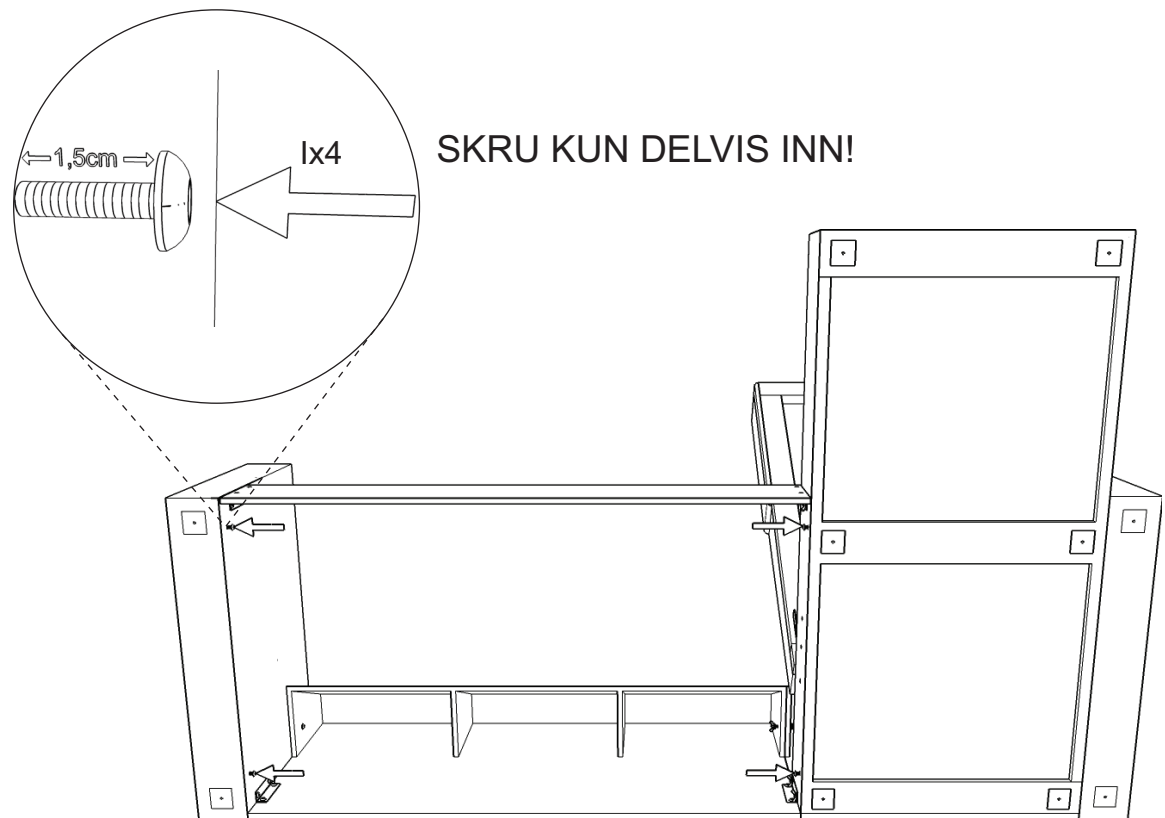

6

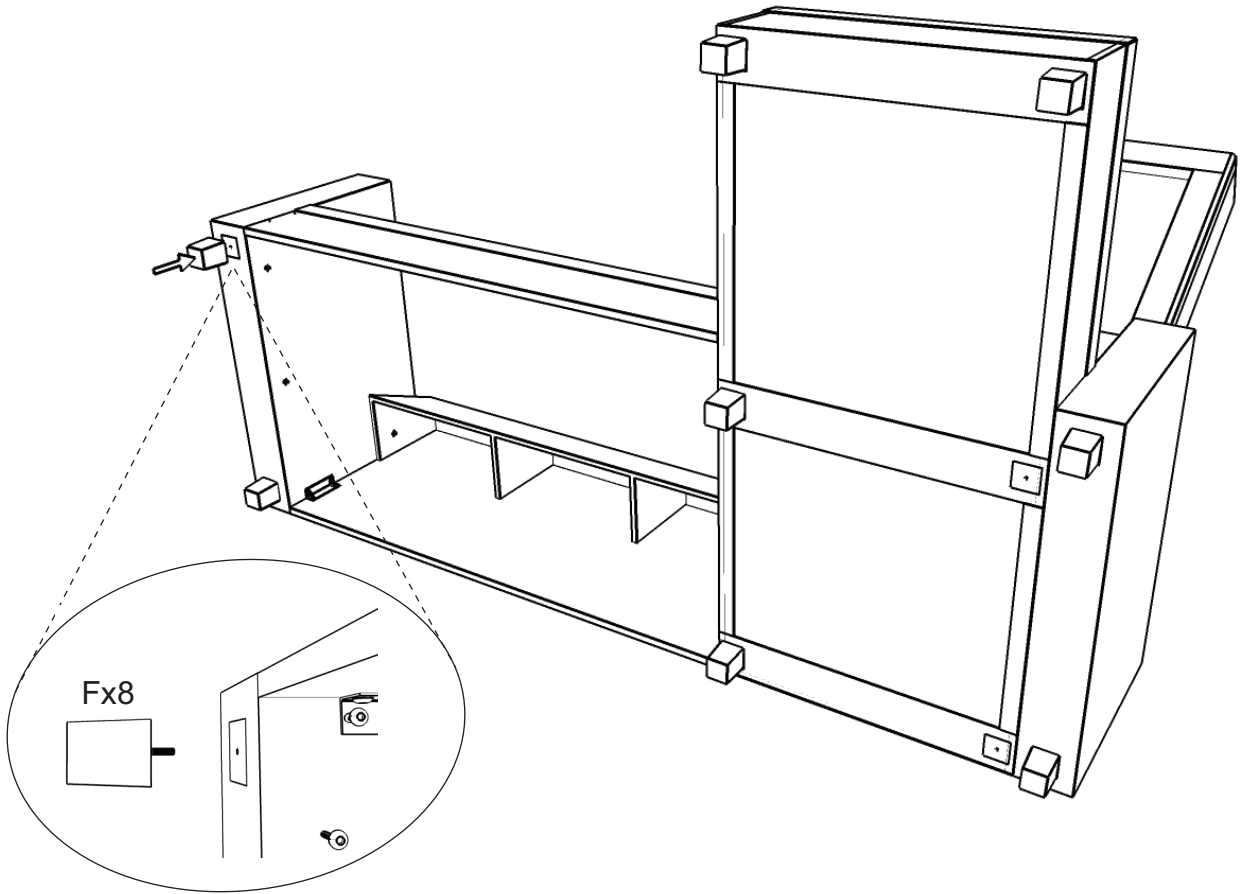

7

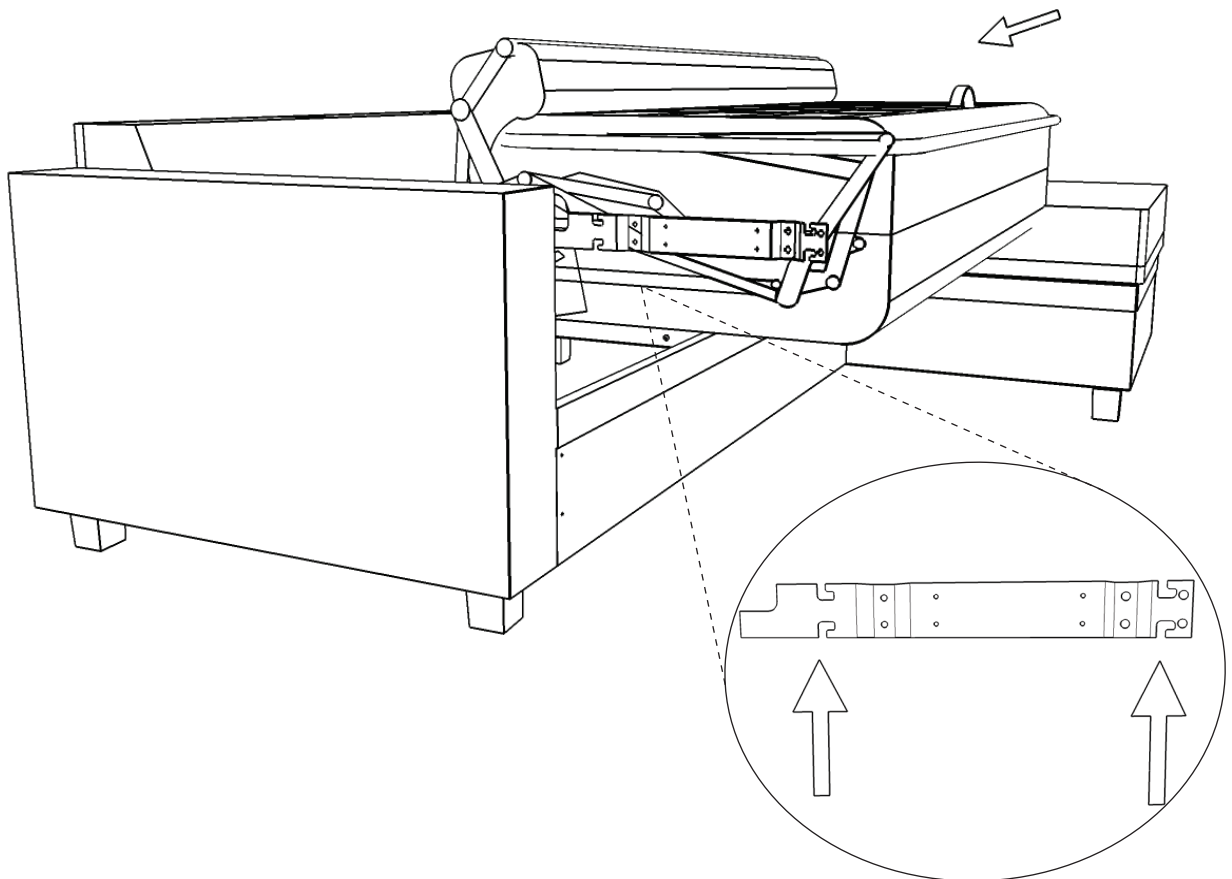

H O V D E N

8

FJERN
TRANSPORTSIKRING.

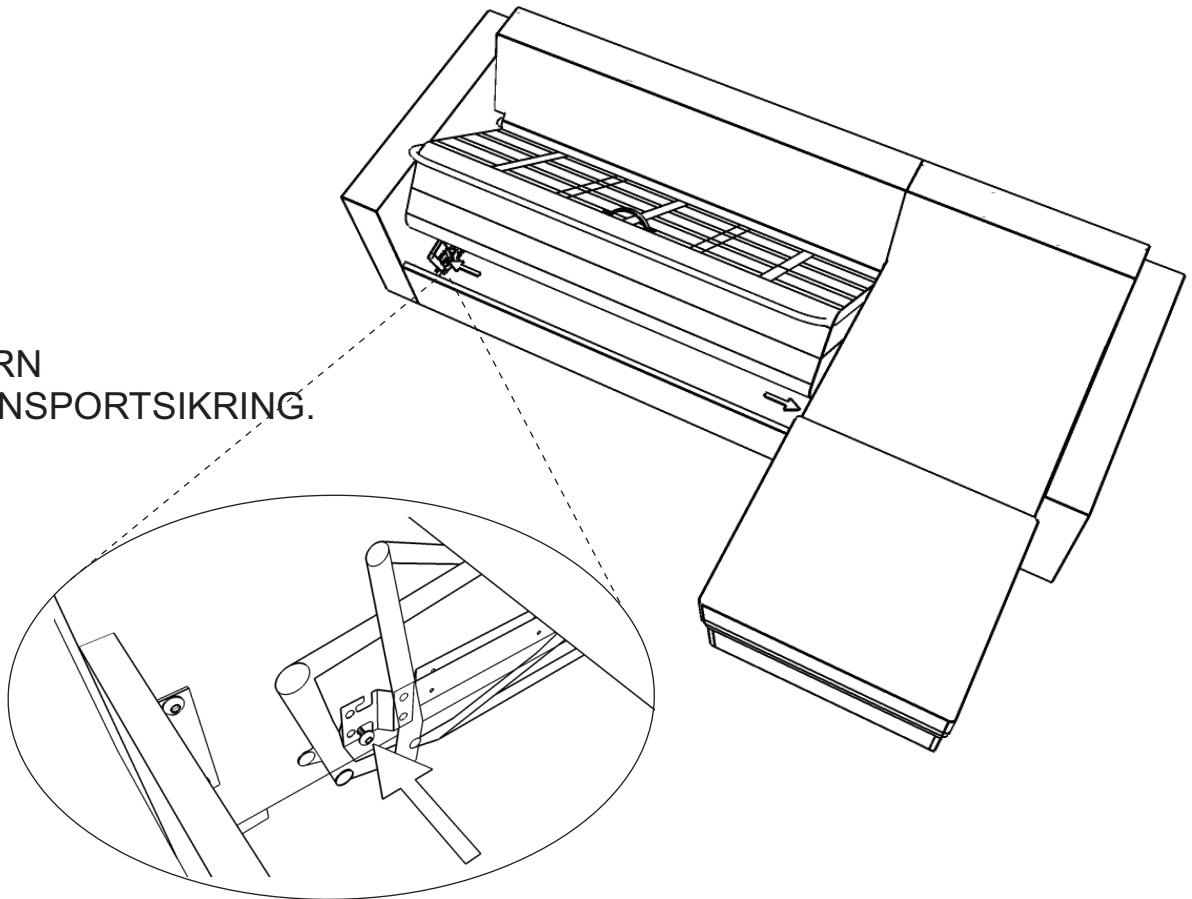

9

LØFT BESLAGET FREM.
VIPP OPP HODEENDEN.
STRAM SKRUENE!

